

# BUILDING STANDARDS



## Leaflet 4

### Velux Roof Lights

Building (Scotland) Act 2003

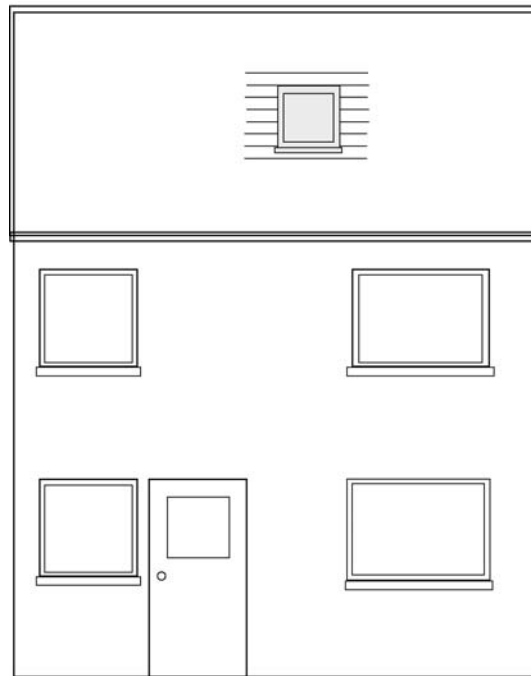

#### Introduction

For the installation of velux windows within the City two permissions will normally be required from the City Council.

- **Building Warrant**
- **Planning Permission**

It is hoped the information provided will assist you to obtain approvals as quickly and as easily as possible.

#### Making an application for Building Warrant

Building warrant is the permission which is required before starting "building" work. The application for building warrant should be made to:

**Building Standards  
Enterprise, Planning and Infrastructure  
Aberdeen City Council  
Business Hub 4  
Marischal College  
Broad Street  
Aberdeen AB10 1AB**

Telephone: **01224 523470**

Fax: **01224 523180**

E-Mail: **pi@aberdeencity.gov.uk**

## Information

The building warrant application form should be carefully completed, and submitted along with the appropriate plans and fees to the above address. Payment should normally be made by crossed cheque made payable to the Aberdeen City Council. Cash or Postal Orders are acceptable. There is a fee scale for building warrant applications dependent on cost of work. There is no neighbour notification procedure for building warrant applications.

Aberdeen City Council is the verifying body for warrant applications submitted within the geographical area of the City. The role of the verifier is to protect the public interest by providing an independent check and, when satisfied, the approval of an application for warrant, and also issue a notification of acceptance of the Completion Certificate submitted by the applicant if they are satisfied that the work complies with the relevant warrant and building regulations.

## Planning Permission

Submission of an application for building warrant does not exempt an applicant from obtaining any other permissions which may be required, for example planning permission.

## Plans

You are required to submit one set of plans for a warrant application. Further sets of plans may be required prior to approval. The plans submitted should normally be in a scale of 1:100 or 1:50 and show the following:

- sufficient elevations, plans and sections to provide a complete representation of the proposed development
- constructional details of all parts of the building
- structural details and design calculations (if required)
- details of plumbing and drainage work (if required)
- details of ventilation and electrical arrangements (if required)

## Location Plans

A Location Plan should be to a scale of 1/1250 or 1/2500 and this should clearly show (*Ordnance Survey base preferred*);

- The location of the proposed development in relation to the nearest road junction
- Existing and proposed buildings
- The extent of the boundaries of the site
- The North point and the scale of the plan
- Detailed guidance on plans to be submitted is given in the Building Procedure (Scotland) Regulations
- In rural areas a map showing the site's relationship to the wider area should also be provided.



© Crown Copyright. Unauthorised reproduction infringes Crown Copyright and may lead to prosecution or civil proceedings. Aberdeen City Council - Licence No. 100023401 (2009)

## Information and Regulations concerned with the installation of Velux Roof Lights

- Provide details of alterations to existing roof trusses, showing information about bridle etc.
- Provide details of the classification of the velux roof light within six metres of the boundary.
- Clarify if the velux roof light requires to be an escape window.
- Provide details of the flashing arrangement around the velux roof light.
- Provide details of the ventilation.
- If the velux roof light is being formed into a totally new apartment other standards could apply. Clarification should be sought on the other regulations concerned, at the address noted below.
- Details of the thermal performance of the glazing in the roof window.

## Notification of work starting on site

When the work is about to start, you should submit the Starting Date Notification Form 1, which will be sent to you or your agent when your building warrant is approved. This form should be sent to the address noted at the bottom of the page. On receipt of the starting date form this will, in most cases, generate a visit from the Building Standards Officer assigned to your project. If the work is of a very minor nature it is likely that a visit will be carried out when the completion certificate has been submitted to the council, as verifier, for acceptance. Each application is assessed on its own specific merits and the regime for inspections will be decided upon this basis.

## Completion of the Works

When the work is finished the 'relevant person' (the applicant, usually the owner, tenant or developer) **must** submit the Completion Certificate to the Council, as verifier, for acceptance, or rejection if the work is incomplete or does not comply with the approved plans and building regulations.

The Completion Certificate (Form No.5) is included with the documents sent out when the building warrant approval documents were issued. Additional forms can be obtained from the Council if necessary.

If electrical work has been carried out, this must also be certified. There are a number of ways of doing this:

- If an approved certifier of construction has carried out the electrical work then that contractor will provide the appropriate certificate, duly completed, for the Council to verify.
- If the electrical contractor or electrician is not an approved certifier of construction then the appropriate certification taken from BS 7671:2001 should be submitted duly completed.
- If the electrical work was not carried out by a qualified electrician, it may be that you will have to have the installation checked by one and the appropriate certificate in accordance with point 2 above submitted.

The Completion Certificate (and the electrical compliance information if appropriate) submitted to the Council will generate a visit from the Building Standards Officer for your project. If the work is of a minor nature, this may be the first visit.

If the work is satisfactory, you or your agent will receive Notification of Acceptance of the Certificate of Completion. This document is important if you decide to sell your property or for mortgage purposes. If selling your property, the purchasing solicitor will insist that the necessary consents have been obtained and that work has been carried in accordance with the approvals granted.

If you do not have the Notification of Acceptance of the Certificate of Completion it may generate problems regarding the sale of the property or affect its value.

**For further advice and copies of all application forms**

Please contact:

**Building Standards  
Enterprise, Planning and Infrastructure  
Aberdeen City Council  
Business Hub 4  
Marischal College  
Broad Street  
Aberdeen AB10 1AB**

Telephone: **01224 523470**

Fax: **01224 523180**

E-Mail: **pi@aberdeencity.gov.uk**

The application reception desk is situated on the Ground Floor (left) Marischal College. Office hours are from 8.30am to 5.00pm Monday to Friday. If you wish to discuss some aspect of your application in detail it is advisable to telephone for an appointment before calling.

**NOTES**

- While anyone may prepare plans this task is best left to an Architect, or Building Consultant or other person experienced in preparing drawings and submitting applications.
- As owner of the building or the person who has applied for and received warrant approval it is in your best interests to appoint an appropriate professional (for example a chartered architect, chartered surveyor or building consultant) to look after your interests on site. It is **not** the intention of the building standards system that the verifying authority provides protection to a client in a contract with a builder.

## Examples of the type and quality of plans required for Installation of Velux Roof Lights

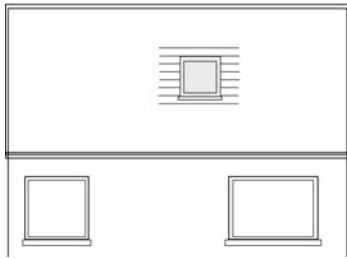

Part Front Elevation  
Scale 1:50

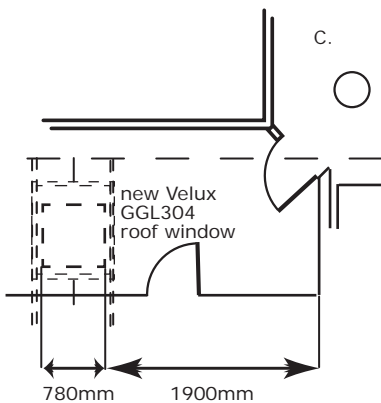

Part First floor plan  
Scale 1:50

- Provide details of alterations to existing roof trusses, showing information about bridles etc.
- Provide details of the classification of the velux roof light within six metres of the boundary.
- Clarify if the velux roof light requires to be an escape window.
- Provide details of the flashing arrangement around the velux roof light.
- Provide details of the ventilation.
- If the velux roof light is being formed into a totally new apartment other regulations could apply. Clarification should be sought on the other regulations concerned.
- Details of the thermal performance of the glazing in the roof window.

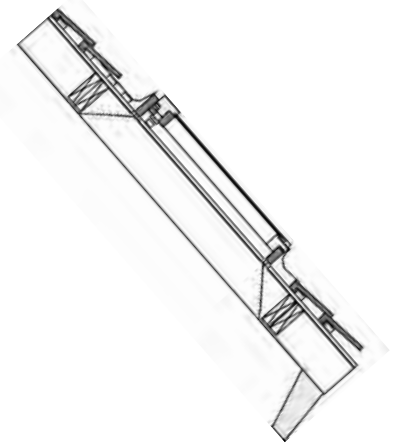

Section  
Scale 1:20